



DC COMPONENTS CO., LTD.

RECTIFIER SPECIALISTS

SMBFJ6.8A
THRU
SMBFJ550A

TECHNICAL SPECIFICATIONS OF TRANSIENT VOLTAGE SUPPRESSOR

VOLTAGE RANGE - 6.8 to 550Volts

PEAK PULSE POWER - 600 Watts

FEATURES

- * Glass passivated junction
- * 600 Watts Peak Pulse Power capability on 10/1000 μ s waveform
- * Excellent clamping capability
- * Low inductance
- * Fast response time

MECHANICAL DATA

- * Case: Molded plastic
- * Epoxy: UL 94V-0 rate flame retardant
- * Lead: MIL-STD-202E, Method 208 guaranteed
- * Polarity: Color band denotes positive end (cathode) except bidirectional types
- * Mounting position: Any
- * Weight: 0.057 gram

MAXIMUM RATINGS AND ELECTRICAL CHARACTERISTICS

Ratings at 25°C ambient temperature unless otherwise specified.
Single phase, half wave, 60Hz, resistive or inductive load.
For capacitive load, derate current by 20%.



SMBFL

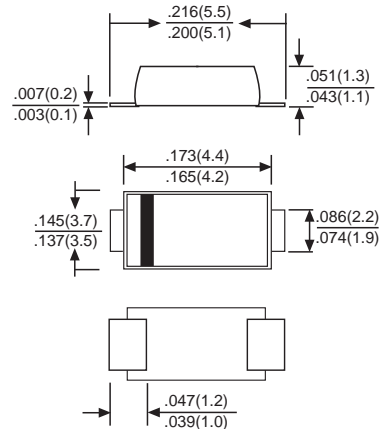

DEVICES FOR BIPOLAR APPLICATIONS

	SYMBOL	VALUE	UNITS
Peak Pulse Power Dissipation on 10/1000 μ s waveform (Note1, Fig.1)	PPPM	600	Watts
Steady State Power Dissipation at TA = 25°C Lead Lengths .375"(9.5mm) (Note 2)	PM(AV)	1.0	Watts
Peak Forward Surge Current, 8.3ms single half sine-wave superimposed on rated load(JEDEC Method) (Note 3)	IFSM	100	Amps
Operating and Storage Temperature Range	TJ, TSTG	-55 to + 150	°C

- NOTES : 1. Non-repetitive current pulse, per Fig.3 and derated above TA = 25°C per Fig. 2.
2. Mounted on Copper Leaf area of 0.5 X 0.5" (12.7 X 12.7mm) per Fig. 5
3. 8.3ms single half sine-wave or equivalent square wave, duty cycle = 4 pulses per minute maximum.

RATING AND CHARACTERISTIC CURVES (SMBFJ6.8A THRU SMBFJ550A)

FIG. 1
PEAK PULSE POWER RATING CURVE

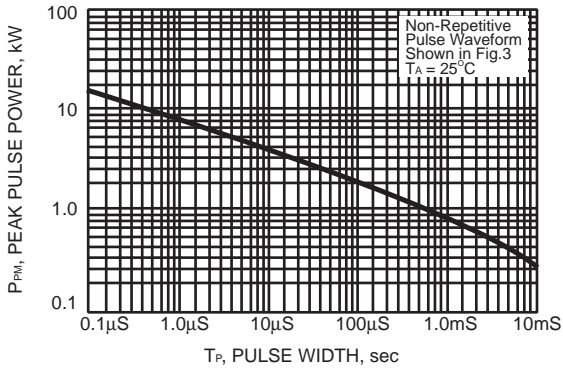

FIG. 2 - PULSE DERATING CURVE

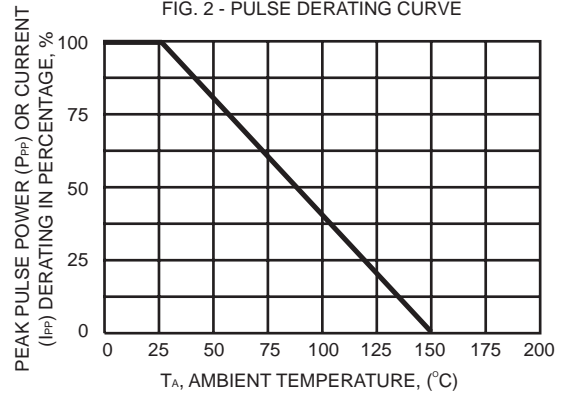

FIG. 3 - PULSE WAVEFORM

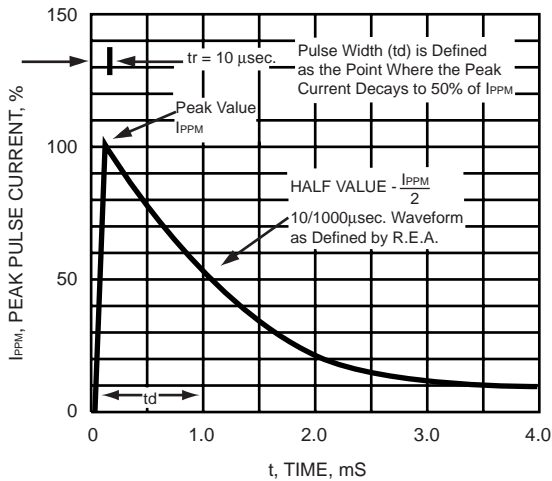

FIG. 4 - TYPICAL JUNCTION CAPACITANCE

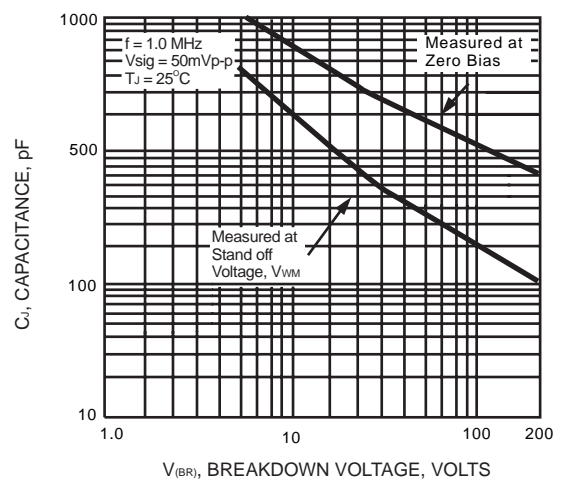
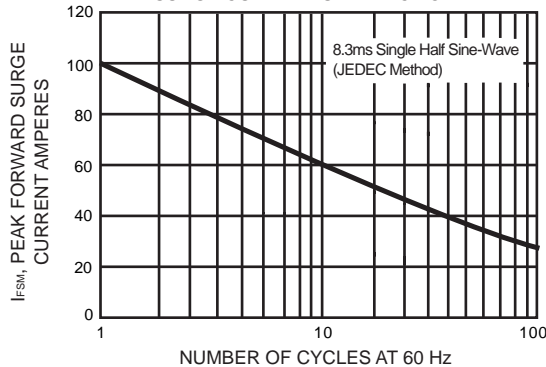

FIG. 5 - MAXIMUM NON-REPETITIVE FORWARD SURGE CURRENT UNIDIRECTIONAL



SMBFJ (600W) SERIES TRANSIENT VOLTAGE SUPPRESSORS

TYPE	Reverse Stand-off Voltage	Breakdown Voltage @ I _T		Test Current	Maximum Reverse Leakage @ V _{RWM}	Maximum Clamping Voltage @ I _{PP}	Maximum Peak Pulse Current
		V _{BR}					
	V _{RWM}	Min. V	Max. V	I _T	I _R	V _C	I _{PP}
	V			mA	μA	V	A
SMBFJ6.8A	5.8	6.45	7.14	10	1000	10.5	58.1
SMBFJ7.5A	6.4	7.13	7.88	10	500	11.3	54.0
SMBFJ8.2A	7.02	7.79	8.61	10	200	12.1	50.4
SMBFJ9.1A	7.78	8.65	9.55	1	50	13.4	45.5
SMBFJ10A	8.55	9.5	10.5	1	10	14.5	42.1
SMBFJ11A	9.4	10.5	11.6	1	5	15.6	39.1
SMBFJ12A	10.2	11.4	12.6	1	5	16.7	36.5
SMBFJ13A	11.1	12.4	13.7	1	1	18.2	33.5
SMBFJ15A	12.8	14.3	15.8	1	1	21.2	28.8
SMBFJ16A	13.6	15.2	16.8	1	1	22.5	27.1
SMBFJ18A	15.3	17.1	18.9	1	1	25.2	24.2
SMBFJ20A	17.1	19	21	1	1	27.7	22.0
SMBFJ22A	18.8	20.9	23.1	1	1	30.6	19.9
SMBFJ24A	20.5	22.8	25.2	1	1	33.2	18.4
SMBFJ27A	23.1	25.7	28.4	1	1	37.5	16.3
SMBFJ30A	25.6	28.5	31.5	1	1	41.4	14.7
SMBFJ33A	28.2	31.4	34.7	1	1	45.7	13.3
SMBFJ36A	30.8	34.2	37.8	1	1	49.9	12.2
SMBFJ39A	33.3	37.1	41	1	1	53.9	11.3
SMBFJ43A	36.8	40.9	45.2	1	1	59.3	10.3
SMBFJ47A	40.2	44.7	49.4	1	1	64.8	9.4
SMBFJ51A	43.6	48.5	53.6	1	1	70.1	8.7
SMBFJ56A	47.8	53.2	58.8	1	1	77	7.9
SMBFJ62A	53	58.9	65.1	1	1	85	7.2
SMBFJ68A	58.1	64.6	71.4	1	1	92	6.6
SMBFJ75A	64.1	71.3	78.8	1	1	103	5.9
SMBFJ82A	70.1	77.9	86.1	1	1	113	5.4
SMBFJ91A	77.8	86.5	95.5	1	1	125	4.9
SMBFJ100A	85.5	95	105	1	1	137	4.5
SMBFJ110A	94	105	116	1	1	152	4.0
SMBFJ120A	102	114	126	1	1	165	3.7
SMBFJ130A	111	124	137	1	1	179	3.4
SMBFJ150A	128	143	158	1	1	207	2.9
SMBFJ160A	136	152	168	1	1	219	2.8
SMBFJ170A	145	162	179	1	1	234	2.6
SMBFJ180A	154	171	189	1	1	246	2.5
SMBFJ200A	171	190	210	1	1	274	2.2
SMBFJ220A	185	209	231	1	1	328	1.9
SMBFJ250A	214	237	263	1	1	344	1.8
SMBFJ300A	256	285	315	1	1	414	1.5
SMBFJ350A	300	332	368	1	1	482	1.3
SMBFJ400A	342	380	420	1	1	548	1.1
SMBFJ440A	376	418	462	1	1	602	1.0
SMBFJ480A	408	456	504	1	1	658	0.9
SMBFJ510A	434	485	535	1	1	698	0.9
SMBFJ530A	450	503.5	556.5	1	1	725	0.8
SMBFJ540A	459	513	567	1	1	740	0.8
SMBFJ550A	467	522.5	577.5	1	1	760	0.8

Disclaimer

Any Customer or user of this document or products described herein in such applications shall assume all risks of such use and will agree to hold *DC COMPONENTS* harmless against all damages.

DC COMPONENTS disclaims any and all liability arising out of the application or use of any product, including consequential or incidental damages. Statement regarding the suitability of products for certain types of applications are based on *DC COMPONENTS*'s knowledge of typical requirements that are often placed on *DC COMPONENTS* products in generic applications. Such statements are not binding statements about the suitability of products for a particular application. It is the customer's responsibility to validate that a particular product with the properties described in the product specification is suitable for use in a particular application.

DC COMPONENTS reserve the right to make modifications, enhancements, improvements, corrections or other changes without further notice to this document and any product described herein, and disclaim any and all liability for any errors, inaccuracies or incompleteness contained in any datasheet or in any other disclosure relating to any product. Parameters provided in datasheets and specifications may vary in different applications and performance may vary over time. All operating parameters, including typical parameters, must be validated for each customer application by the customer's technical experts. Product specifications do not expand or otherwise modify *DC COMPONENTS*'s terms and conditions of purchase, including but not limited to the warranty expressed therein.

Unless otherwise in writing, *DC COMPONENTS* products are intended for use as general electronic components in standard applications (eg: Consumer electronic, Computer equipment, Office equipment, etc.), and not recommended for use in a high specific application where a failure or malfunction of the device could result in human injury or death (eg: Aerospace equipment, Submarine cables, Combustion equipment, Safety devices, Life support systems, etc.)

Customers using or selling *DC COMPONENTS* products not expressly indicated for use in such applications do so at their own risk. If customer intended to use *DC COMPONENTS* standard quality grade devices for applications not envisioned by *DC COMPONENTS*, please contact our sales representatives in advance.



DC COMPONENTS CO., LTD.