



*DC COMPONENTS CO., LTD.*

RECTIFIER SPECIALISTS

ES3A  
THRU  
ES3J

**TECHNICAL SPECIFICATIONS OF SURFACE MOUNT SUPER FAST RECTIFIER**

**VOLTAGE RANGE 50 to 600 Volts**

**CURRENT 3.0 Ampere**

**FEATURES**

- \* Ideal for surface mounted applications
- \* Low leakage current
- \* Glass passivated junction

**MECHANICAL DATA**

- \* Case: Molded plastic
- \* Epoxy: UL 94V-0 rate flame retardant
- \* Terminals: Solder plated, solderable per MIL-STD-750, Method 2026
- \* Polarity: As marked
- \* Mounting position: Any
- \* Weight: 0.24 gram

**MAXIMUM RATINGS AND ELECTRICAL CHARACTERISTICS**

Ratings at 25 °C ambient temperature unless otherwise specified.  
Single phase, half wave, 60 Hz, resistive or inductive load.  
For capacitive load, derate current by 20%.



SMB ( DO-214AA )

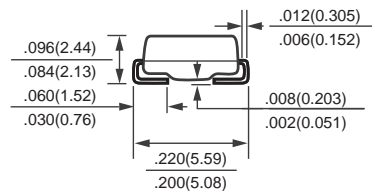
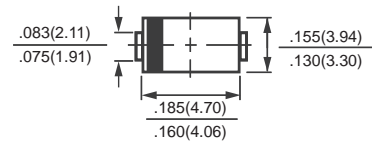

Dimensions in inches and (millimeters)

	SYMBOL	ES3A	ES3B	ES3C	ES3D	ES3E	ES3G	ES3J	UNITS
Maximum Recurrent Peak Reverse Voltage	V <sub>RRM</sub>	50	100	150	200	300	400	600	Volts
Maximum RMS Voltage	V <sub>RMS</sub>	35	70	105	140	210	280	420	Volts
Maximum DC Blocking Voltage	V <sub>DC</sub>	50	100	150	200	300	400	600	Volts
Maximum Average Forward Rectified Current at T <sub>A</sub> = 55°C	I <sub>O</sub>	3.0							Amps
Peak Forward Surge Current I <sub>FM</sub> (surge): 8.3 ms single half sine-wave superimposed on rated load (JEDEC method)	I <sub>FSM</sub>	100							Amps
Maximum Forward Voltage at 3.0A DC	V <sub>F</sub>	0.95			1.25		1.7		Volts
Maximum DC Reverse Current at Rated DC Blocking Voltage	I <sub>R</sub>	@T <sub>A</sub> = 25°C							μAmps
		@T <sub>A</sub> = 100°C							
Maximum Reverse Recovery Time (Note 1)	t <sub>rr</sub>	35							nSec
Typical Junction Capacitance (Note 2)	C <sub>J</sub>	60							pF
Operating and Storage Temperature Range	T <sub>J</sub> , T <sub>STG</sub>	-65 to +175							°C

NOTES : 1. Test Conditions: I<sub>F</sub>=0.5A, I<sub>R</sub>=1.0A, I<sub>RR</sub>=0.25A.  
2. Measured at 1.0 MHz and applied reverse voltage of 4.0 volts.

# RATING AND CHARACTERISTIC CURVES (ES3A THRU ES3J)

FIG. 1 - TYPICAL FORWARD CURRENT DERATING CURVE

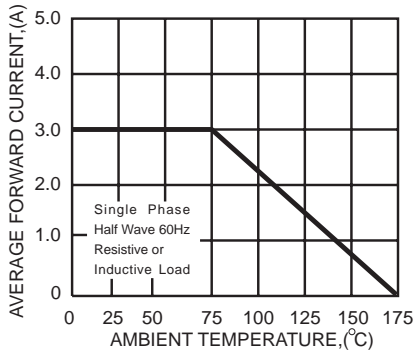

FIG. 2 - TYPICAL INSTANTANEOUS FORWARD CHARACTERISTICS

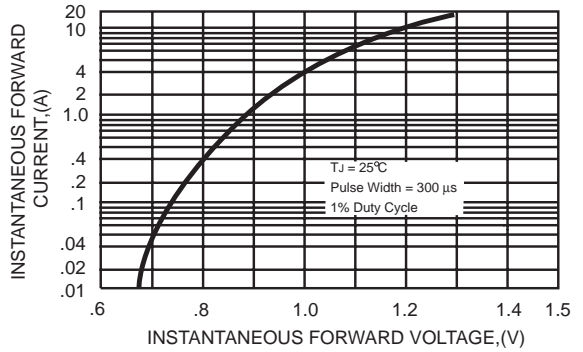

FIG. 3 - MAXIMUM NON-REPETITIVE FORWARD SURGE CURRENT

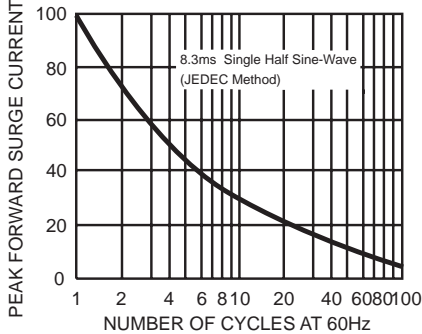

FIG. 4 - TYPICAL REVERSE CHARACTERISTICS

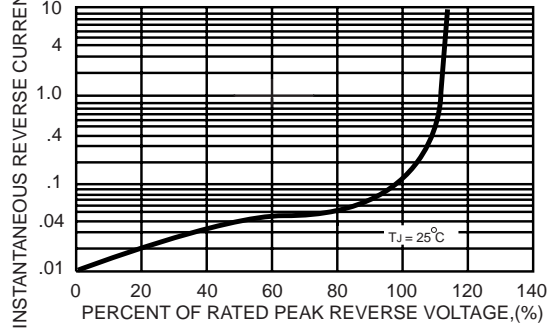

FIG. 5 - TEST CIRCUIT DIAGRAM AND REVERSE RECOVERY TIME CHARACTERISTIC

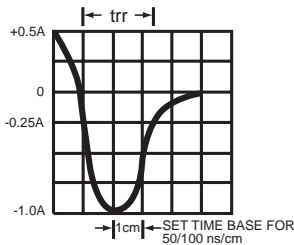
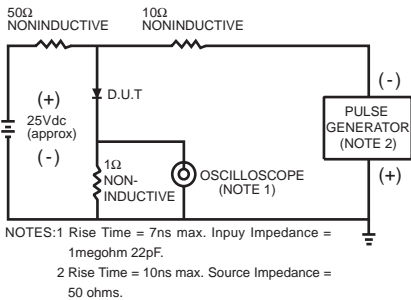
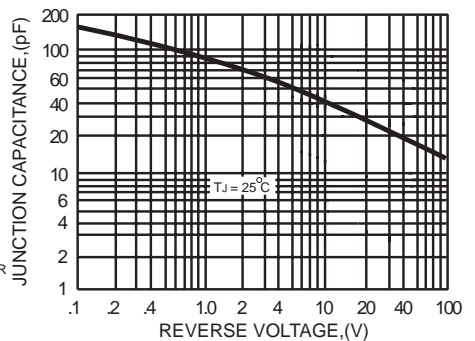

FIG. 6 - TYPICAL JUNCTION CAPACITANCE



DC COMPONENTS CO., LTD.