



DC COMPONENTS CO., LTD.
DISCRETE SEMICONDUCTORS

DCR150-4
THRU
DCR150-8

TECHNICAL SPECIFICATIONS OF SENSITIVE GATE SILICON CONTROLLED RECTIFIERS
VOLTAGE RANGE - 200 to 600 Volts CURRENT - 1.5 Amperes

Description

- * Driven directly with IC and MOS device
- * Feature proprietary, void-free glass passivated chips
- * Available in voltage ratings from 200 to 600 volts
- * Sensitive gate trigger current
- * Designed for high volume, line-powered control application in relay lamp drivers, small motor controls, gate drivers for large thyristors

Pinning

1 = Cathode, 2 = Gate, 3 = Anode

Absolute Maximum Ratings (TA=25°C)

Characteristic	Symbol	Rating	Unit
Peak Repetitive Off-State Voltage and Reverse Voltage	DCR150-4 DCR150-6 DCR150-8 V _{DRM} , V _{VRRM}	200 400 600	V
On-State RMS Current (TA=57°C, 180° Conduction Angles)	I _{T(RMS)}	1.5	A
Peak Non-repetitive Surge Current (1/2 Cycle, Sine Wave 60Hz)	I _{TSM}	15	A
Forward Peak Gate Current	I _{GM}	1.0	A
Forward Peak Gate Power Dissipation	P _{GM}	0.1	W
Forward Average Gate Power Dissipation	P _{G(AV)}	0.01	W
Operating Junction Temperature	T _J	-40 to +110	°C
Storage Temperature	T _{STG}	-40 to +150	°C

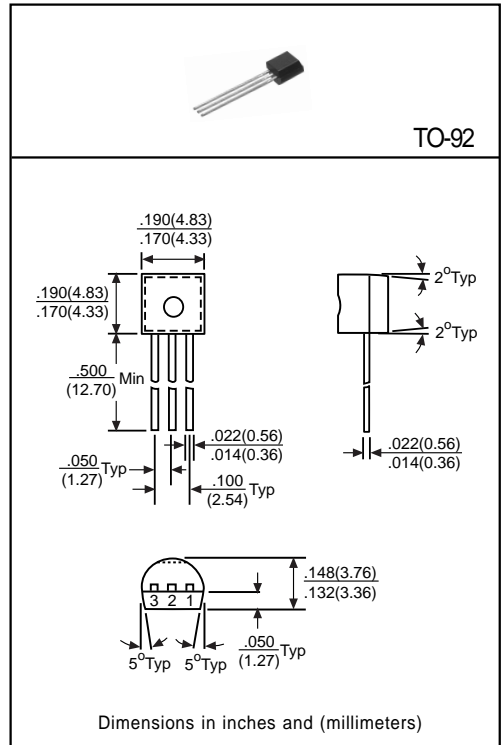

Electrical Characteristics

(Ratings at 25°C ambient temperature unless otherwise specified)

Characteristic	Symbol	Min	Typ	Max	Unit	Test Conditions
Peak Repetitive Forward or Reverse Off-State Blocking Current	T _J =25°C	-	-	10	μA	V _{AK} =Rated V _{DRM} or V _{VRRM} R _{GK} =1KΩ
	T _J =110°C	-	-	200		
Peak Forward On-State Voltage	V _{TM}	-	-	1.7	V	I _{TM} =1A Peak
Continuous DC Gate Trigger Current	I _{GT}	-	-	200	μA	V _{AK} =7V DC, R _L =100Ω
Continuous DC Gate Trigger Voltage	V _{GT}	-	-	0.8	V	V _{AK} =7V DC, R _L =100Ω
DC Holding Current	I _H	-	-	5.0	mA	R _{GK} =1KΩ
Critical Rate-of-Rise of Off-State Voltage	dv/dt	-	25	-	V/μS	R _{GK} =1KΩ
Gate Controlled Turn-on Time(t _d +t _r)	T _{gt}	-	3.5	-	μsec	I _{GT} =10mA
Thermal Resistance, Junction to Case	R _{θJC}	-	75	-	°C/W	-